



## Gerätehaus "HB" serie 5x2.5

Projektabmessungen

5 × 2.5 / 10.5 m<sup>2</sup>

Hausset

**2.104 €**

### Balken



45 mm



65 mm  
+ 584 €

# Projektplanung



5 000

2 500

10.03

M<sup>2</sup>



# Разрез

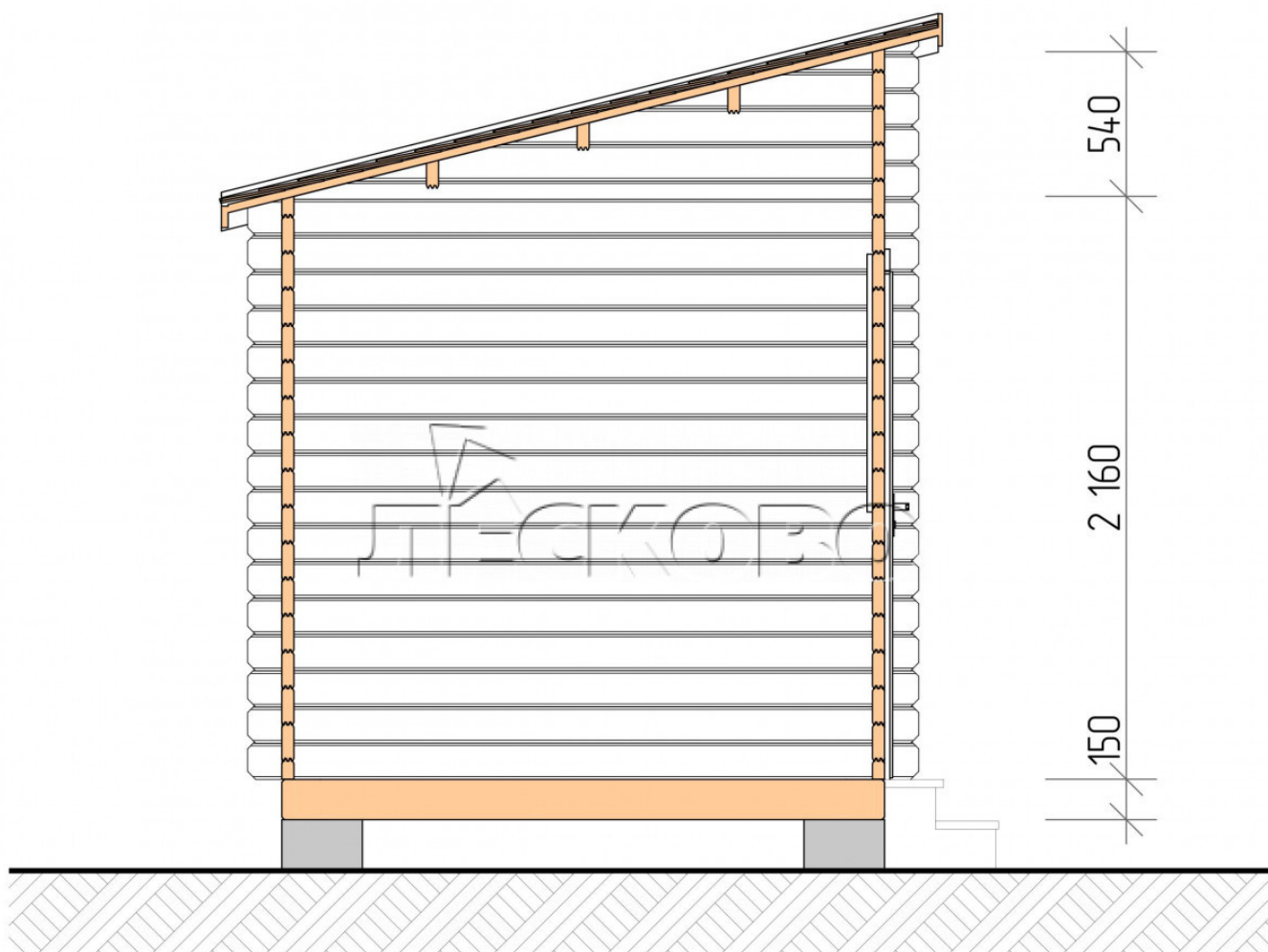

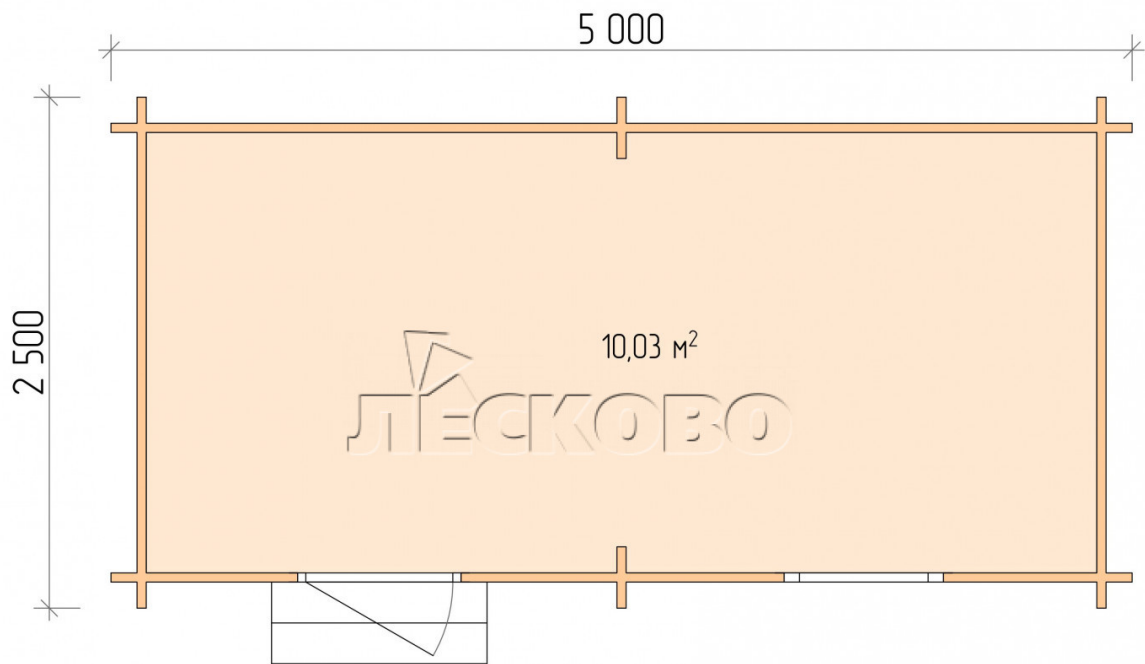

#### Haus Kit

- Wandbausatz: Minikammer-Trockenkammer 44 × 145 mm mit Schalen für das Projekt. Das Baumaterial ist Fichte, Kiefer (GOST 8486). Luftfeuchtigkeit 12-14%. Die Höhe der Mauern beträgt 1,35 m;
- Baumstämme, unterer Kabelbaum: Brett 45 × 145 mm, Kammertrocknung 10-12%;
- Boden: Diele 35 mm, Kammertrocknung;
- Decke: Imitation einer Stange 20 × 135 mm, Kammertrocknung;
- Holzfenster, Glas 4 mm., Single. Behandlung mit einem farblosen Antiseptikum. Hardware;



0.87×0.78 м.1 шт.

- Holztüren;



1 шт.

7. Platbands: trocken gehobelte Platte 20 × 100 mm;

8. Dach: Schindeln «Shinglas»;

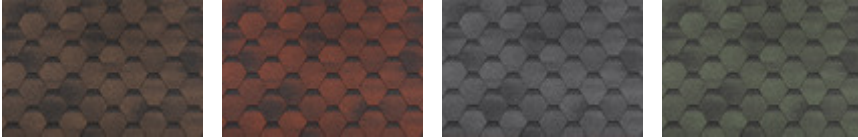

9. Fußleiste 35 mm.

+7 (4942) 499-770

156014, г. Кострома, ул. Базовая, д. 8